

# STAINLESS STEEL GROOVED-END FITTINGS

SS-21 Reducing Tee (Gr X Gr X Gr)  
 SS-50 Concentric Reducer  
 SS-21 Reducing Tee (Gr X Gr X FT)  
 SS-50F Concentric Reducer (Gr X FT)



Job Name:	
Job Location:	
Engineer:	
Contractor:	
Tag:	
PO#:	
Rep:	
Wholesale Dist.:	

The Shurjoint Model SS-21 & SS-50 stainless steel fittings are investment cast in sizes to 8" and sand cast or wrought in sizes 10" - 24". Materials are in compliance with NSF/ANSI 61 & 372 for potable water service applications.

Shurjoint stainless steel fitting pressure ratings conform to the ratings of Model 7707 coupling.

For Fire Protection pressure rating, listing, and approval information, refer to Data Sheet B-42 or visit [www.shurjoint.com](http://www.shurjoint.com) for details or contact Shurjoint.

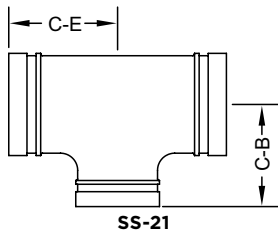

## DIMENSIONS

NOMINAL SIZE	PIPE O.D.	SS-21 REDUCING TEE			SS-50 CONCENTRIC REDUCER	
		C-E	C-B	WEIGHT	E-E	WEIGHT
in	in	in	in	lb	in	lb
mm	mm	mm	mm	kg	mm	kg
1-1/4 x 1	1660 x 1315	2.75	2.75	1.2	2.50	0.5
30 x 25	42.2 x 33.4	.70	.70	0.6	.64	0.2
1-1/2 x 1	1900 x 1315	2.75	2.75	1.3	2.50	0.6
40 x 25	48.3 x 33.4	.70	.70	0.6	.64	0.3
1-1/2 x 1-1/4	1900 x 1660	2.75	2.75	1.3	2.50	0.7
40 x 32	48.3 x 42.2	.70	.70	0.6	.64	0.3
2 x 1	2375 x 1315	2.75	2.75	1.5	2.50	0.8
50 x 25	60.3 x 33.4	.70	.70	0.7	.64	0.3
2 x 1-1/4	2375 x 1660	2.75	2.75	1.8	2.50	0.7
50 x 32	60.3 x 42.2	.70	.70	0.8	.64	0.7
2 x 1-1/2	2375 x 1900	2.75	2.75	1.8	2.50	0.7
50 x 40	60.3 x 48.3	.70	.70	0.8	.64	0.3
2-1/2 x 1	2875 x 1315	3.74	3.74	2.0	2.50	0.9
65 x 25	73.0 x 33.4	.95	.95	0.9	.64	0.4
2-1/2 x 1-1/4	2875 x 1660	3.74	3.74	2.0	2.50	1.1
65 x 32	73.0 x 42.2	.95	.95	0.9	.64	0.5
2-1/2 x 1-1/2	2875 x 1900	3.74	3.74	2.0	2.50	1.2
65 x 40	73.0 x 48.3	.95	.95	0.9	.64	0.5
2-1/2 x 2	2875 x 2375	3.00	3.00	4.1	2.50	1.1
65 x 50	73.0 x 60.3	.76	.76	1.9	.64	0.5
76.1 x 25 mm	3000 x 1315	3.74	3.74	2.0	2.50	0.9
	76.1 x 33.4	.95	.95	0.9	.64	0.4
76.1 x 32 mm	3000 x 1660	3.74	3.74	2.0	2.50	1.1
	76.1 x 42.2	.95	.95	0.9	.64	0.5
76.1 x 40 mm	3000 x 1900	3.74	3.74	2.0	2.50	1.2
	76.1 x 48.3	.95	.95	0.9	.64	0.5
76.1 x 50 mm	3000 x 2375	3.00	3.00	3.3	2.50	1.1
	76.1 x 60.3	.76	.76	1.5	.64	0.5
3 x 1-1/4	3500 x 1660	4.25	4.25	3.5	2.50	1.1
80 x 32	88.9 x 42.2	1.08	1.08	1.6	.64	0.5
3 x 1-1/2	3500 x 1900	4.25	4.25	2.9	2.50	1.5
80 x 40	88.9 x 48.3	1.08	1.08	1.3	.64	0.6
3 x 2	3500 x 2375	4.25	4.25	4.6	2.50	1.3
80 x 50	88.9 x 60.3	1.08	1.08	2.1	.64	0.6
3 x 2-1/2	3500 x 2875	3.74	3.27	6	3.50	2.2
80 x 65	88.9 x 73.0	.95	.83	2.7	.89	1.0
80 x 76.1 mm	3500 x 3000	3.74	3.27	4.6	3.50	2.2
	88.9 x 76.1	.95	.83	2.1	.89	1.0
4 x 2	4500 x 2375	5.00	5.00	7.3	3.00	2.2
100 x 50	114.3 x 60.3	1.27	1.27	3.3	.76	1.0
4 x 2-1/2	4500 x 2875	4.49	3.86	8.8	4.00	3.1
100 x 65	114.3 x 73.0	1.14	.98	.4	1.02	1.4
100 x 76.1 mm	4500 x 3000	4.49	3.86	9	4.00	3.1
	114.3 x 76.1	1.14	.98	4.1	1.02	1.4

NOMINAL SIZE	PIPE O.D.	SS-21 REDUCING TEE			SS-50 CONCENTRIC REDUCER	
		C-E	C-B	WEIGHT	E-E	WEIGHT
in	in	in	in	lb	in	lb
mm	mm	mm	mm	kg	mm	kg
4 x 3	4.500 x 3.500	4.49	3.86	7	3.00	2.2
100 x 80	114.3 x 88.9	114	98	3.2	76	1.0
139.7 x 100 mm	5.500 x 4.500	5.5	5.5	11.2	3.50	3.5
125 x 100	139.7 x 114.3	140	140	5.1	89	1.6
5 x 4	5.563 x 4.500	5.5	5.5	11.2	3.50	3.5
125 x 100	141.3 x 114.3	140	140	5.1	89	1.6
165.1 x 80 mm	6.500 x 3.500	5.91	5.91	15.6	4.00	5.1
	165.1 x 88.9	150	150	7.1	102	2.3
165.1 x 100 mm	6.500 x 4.500	6.50	6.50	19.4	4.00	5.1
	165.1 x 114.3	165	165	8.8	102	2.3
165.1 x 139.7 mm	6.500 x 5.500	6.50	6.50	19.4	4.00	5.7
	165.1 x 139.7	165	165	8.8	102	2.6
6 x 3	6.625 x 3.500	5.91	5.91	15.6	4.00	5.1
150 x 80	168.3 x 88.9	150	150	7.1	102	2.3
6 x 4	6.625 x 4.500	6.50	6.50	19.4	4.00	5.1
150 x 100	168.3 x 114.3	165	165	8.8	102	2.3
6 x 5	6.625 x 5.563	6.50	6.50	19.4	4.00	5.7
150 x 125	168.3 x 141.3	165	165	8.8	102	2.6
8 x 4	8.625 x 4.500	7.76	7.76	35.4	5.00	9.5
200 x 100	219.1 x 114.3	197	197	16.1	127	4.3
8 x 5	8.625 x 5.563	7.76	7.76	28.6	5.00	11.9
200 x 125	219.1 x 141.3	197	197	13	127	5.4
8 x 6	8.625 x 6.625	7.76	7.76	54.1	5.00	9.5
200 x 150	219.1 x 168.3	197	197	24.6	127	4.3
10 x 6	10.750 x 6.625	9.02	9.02	59.2	6.00	18.3
250 x 150	273.0 x 168.3	229	229	26.9	152	8.3
10 x 8	10.750 x 8.625	9.02	9.02	60.1	6.00	19.1
250 x 200	273.0 x 219.1	229	229	27.3	152	8.7
12 x 8	12.750 x 8.625	10*	10	56.1	7.00	49.5
300 x 200	323.9 x 219.1	254	254	25.5	178	22.0
12 x 10	12.750 x 10.750	10*	10	57.2	7.00	23.1
300 x 250	323.9 x 273.0	254	254	26	178	11.3
200 JIS x 100 mm	8.516 x 4.500	7.76	7.76	35.4	5.00	9.5
	216.3 x 114.3	197	197	16.1	127	4.3
200 JIS x 125 mm	8.516 x 5.500	7.76	7.76	28.6	5.00	11.9
	216.3 x 139.7	197	197	13	127	5.4
200 JIS x 165.1 mm	8.516 x 6.500	7.76	7.76	54.1	5.00	9.5
	216.3 x 165.1	197	197	24.6	127	4.3
250 JIS x 165.1 mm	10.528 x 6.500	9.02	9.02	59.2	6.00	18.3
	267.4 x 165.1	229	229	26.9	152	8.3
250 JIS x 200 JIS	10.528 x 8.516	9.02	9.02	60.1	6.00	19.1
	267.4 x 216.3	229	229	27.3	152	8.7
300 JIS x 200 JIS	12.539 x 8.516	10*	10	56.1	7.00	49.5
	318.5 x 216.3	254	254	25.5	178	22.0
300 JIS x 250 JIS	12.539 x 10.528	10*	10	57.2	7.00	23.1
	318.5 x 267.4	254	254	26	178	11.3

# STAINLESS STEEL GROOVED-END FITTINGS

- SS-21 Reducing Tee (Gr X Gr X Gr)
- SS-50 Concentric Reducer
- SS-21F Reducing Tee (Gr X Gr X FT)
- SS-50F Concentric Reducer (Gr X FT)

## MATERIAL SPECIFICATIONS

### FITTING BODY:

- Type 304 stainless steel to ASTM A351 CF8 or A743 Gr. CF
- Type316 to ASTMA743CF8M
- Type316L to ASTMA743CF3M
- Type316Ti to ASTMA240
- Duplex 2205 to ASTMA890 4A
- Super Duplex 2507 to ASTMA8905A
- Duplex 254SMO to ASTM A351CK3McuN

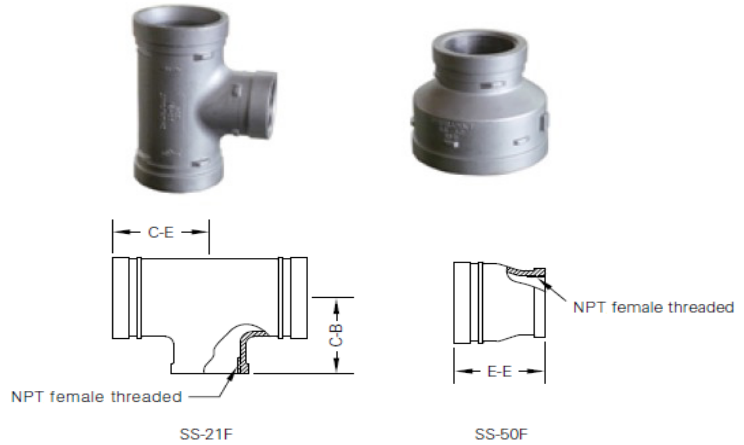

## DIMENSIONS

NOMINAL SIZE	PIPE O.D.	SS-21F REDUCING TEE			SS-50F CONCENTRIC REDUCER	
		C-E	C-B	WEIGHT	E-E	WEIGHT
in	in	in	in	lb	in	lb
mm	mm	mm	mm	kg	mm	kg
2 x 1	2.375 x 1.315	3.27	3.27	4.0	-	-
50 x 30	60.3 x 33.4	83	83	1.8	-	-
2" x 1½"	2.375 x 1.900	3.27	3.27	4.0	-	-
50 x 40	60.3 x 33.4	83	83	1.8	-	-
2½" x 2"	2.875 x 2.375	3.74	3.74	9.0	3.50	2.4
65 x 50	73.0 x 60.3	95	95	4.1	89	1.1
3" x 2"	3.500 x 2.375	3.74	3.27	10.1	3.50	2.4
80 x 50	88.9 x 60.3	95	83	4.6	89	1.3
4" x 2"	4.500 x 2.375	4.50	3.63	16.1	4.00	7.7
100 x 50	114.3 x 60.3	114	92	7.3	102	3.5
6" x 2"	6.625 x 2.375	6.50	6.50	27.1	-	-
150 x 50	168.3 x 60.3	165	165	12.3	-	-

The Shurjoint Model SS-21F & SS-50F stainless steel fittings are investment cast and provide a female NPT connection on the reduced branch. Materials are in compliance with NSF/ANSI 81 and 372 for potable water service applications.

## GENERAL NOTES

- Maximum Working Pressure (CWP) listed is the maximum cold water pressure for general piping services tested to ASTM F1476 and or AWWA C606 methods. Figures listed are based on roll- or cut-grooved standard wall carbon steel pipe. For other pipe schedules or pipe materials, contact Shurjoint for additional information.
- Max. End Load is calculated based on the maximum working pressure (CWP).
- Listed and or Approved Pressures are pressure ratings for fire protection systems, tested and approved by various approval bodies. Please always refer to the latest approval data posted on the Shurjoint website.
- Field Joint Test: For one time only the system may be tested hydrostatically at 1.5 times the maximum working pressure listed (AWWA C606 5.2.3).
- Warning: Piping systems must always be depressurized and drained before attempting disassembly and or removal of any components.
- The 10 Year Limited Warranty applies to manufacturing defects only and does not cover severe service/temperature applications or wear parts.
- Shurjoint reserves the right to change specifications, designs and or standard without notice and without incurring any obligations.