

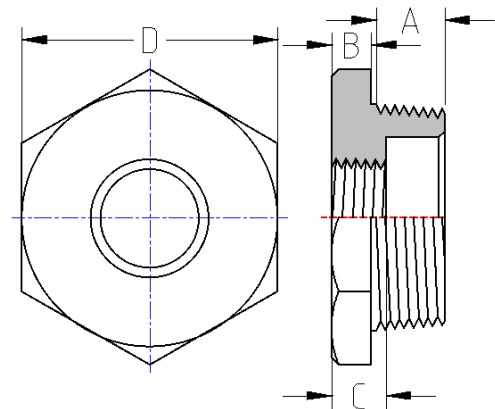

Threaded Hex Bushing  
MSS SP-114 Pattern  
**150# Cast Stainless Steel**  
Inches / Pounds



Nominal Pipe Size	External Thread Length Min. (A)	Height of Head (B)	Internal Thread Length Min. (C)	Nominal Width Across Flats (D)	Nominal Metal Thickness**	Approx. Weight (in Pounds)
1/4" X 1/8"	0.46	0.142	0.276	0.591	-	0.02
3/8" X 1/8"	0.512	0.173	0.276	0.681	-	0.04
3/8" X 1/4"	0.512	0.173	0.416	0.681	-	0.04
1/2" X 1/8"	0.571	0.209	0.276	0.870	-	0.08
1/2" X 1/4"	0.571	0.209	0.416	0.870	-	0.11
1/2" X 3/8"	0.571	0.209	0.421	0.870	-	0.06
3/4" X 1/8"	0.630	0.236	0.276	1.201	-	0.13
3/4" X 1/4"	0.630	0.236	0.416	1.201	-	0.19
3/4" X 3/8"	0.630	0.236	0.421	1.201	-	0.12
3/4" X 1/2"	0.630	0.236	0.543	1.201	-	0.13
1" X 1/8"	0.768	0.268	0.276	1.362	-	0.31
1" X 1/4"	0.768	0.268	0.416	1.362	-	0.38
1" X 3/8"	0.768	0.268	0.421	1.362	-	0.21
1" X 1/2"	0.768	0.268	0.543	1.362	-	0.31
1" X 3/4"	0.768	0.268	0.563	1.362	-	0.23
1-1/4" X 1/8"	0.823	0.295	0.276	1.740	-	0.39
1-1/4" X 1/4"	0.823	0.295	0.416	1.740	0.181	0.58
1-1/4" X 3/8"	0.823	0.295	0.421	1.740	0.181	0.57
1-1/4" X 1/2"	0.823	0.295	0.543	1.740	0.181	0.56
1-1/4" X 3/4"	0.823	0.295	0.563	1.740	-	0.54
1-1/4" X 1"	0.823	0.295	0.693	1.740	-	0.42

**\*The material composition and quality comply with ASTM A351/A351M**

**"Standard Specification for Castings, Austenitic, for Pressure-Containing Parts"**

**\*NPT Threads on all fittings conform to ASME B1.20.1**

**\*Dimensions comply with MSS SP-114**

**\*\* Patterns shall be designed to produce castings of metal thickness given in table. Metal thickness at no point shall be less than 90% of the nominal metal thickness value.**



Threaded Hex Bushing  
MSS SP-114 Pattern  
**150# Cast Stainless Steel**

Inches / Pounds

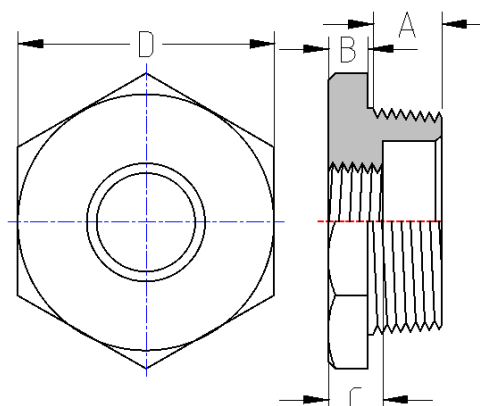

Nominal Pipe Size	External Thread Length Min. (A)	Height of Head (B)	Internal Thread Length Min. (C)	Nominal Width Across Flats (D)	Nominal Metal Thickness**	Approx. Weight (in Pounds)
1-1/2" X 1/4"	0.823	0.323	0.416	1.988	0.201	0.75
1-1/2" X 3/8"	0.823	0.323	0.421	1.988	0.201	0.73
1-1/2" X 1/2"	0.823	0.323	0.543	1.988	0.201	0.74
1-1/2" X 3/4"	0.823	0.323	0.563	1.988	0.201	0.69
1-1/2" X 1"	0.823	0.323	0.693	1.988	-	0.65
1-1/2" X 1-1/4"	0.823	0.323	0.720	1.988	-	0.42
2" X 3/8"	0.894	0.354	0.421	2.480	0.220	1.15
2" X 1/2"	0.894	0.354	0.543	2.480	0.220	1.12
2" X 3/4"	0.894	0.354	0.563	2.480	0.220	1.23
2" X 1"	0.894	0.354	0.693	2.480	0.220	1.19
2" X 1-1/4"	0.894	0.354	0.720	2.480	-	1.18
2" X 1-1/2"	0.894	0.354	0.732	2.480	-	1.06
2-1/2" X 1/2"	1.071	0.394	0.543	2.992	0.240	2.04
2-1/2" X 3/4"	1.071	0.394	0.563	2.992	0.240	2.04
2-1/2" X 1"	1.071	0.394	0.693	2.992	0.240	2.03
2-1/2" X 1-1/4"	1.071	0.394	0.720	2.992	0.240	2.04
2-1/2" X 1-1/2"	1.071	0.394	0.732	2.992	-	2.04
2-1/2" X 2"	1.071	0.394	0.772	2.992	-	2.00

**\*The material composition and quality comply with ASTM A351/A351M "Standard Specification for Castings, Austenitic, for Pressure-Containing Parts"**  
**\*NPT Threads on all fittings conform to ASME B1.20.1**  
**\*Dimensions comply with MSS SP-114**  
**\*\* Patterns shall be designed to produce castings of metal thickness given in table. Metal thickness at no point shall be less than 90% of the nominal metal thickness value.**



Threaded Hex Bushing  
MSS SP-114 Pattern  
**150# Cast Stainless Steel**

Inches / Pounds

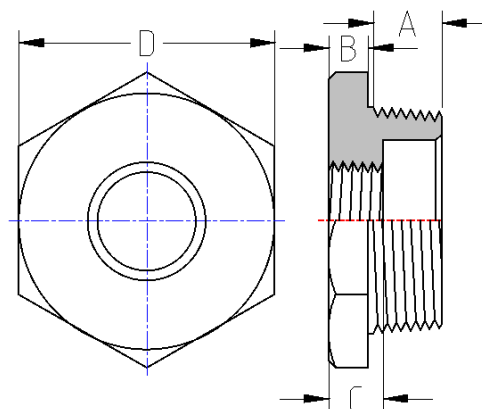

Nominal Pipe Size	External Thread Length Min. (A)	Height of Head (B)	Internal Thread Length Min. (C)	Nominal Width Across Flats (D)	Nominal Metal Thickness**	Approx. Weight (in Pounds)
3" X 1"	1.130	0.421	0.693	3.488	0.260	3.27
3" X 1-1/4"	1.130	0.421	0.720	3.488	0.260	3.26
3" X 1-1/2"	1.130	0.421	0.732	3.488	0.260	3.14
3" X 2"	1.130	0.421	0.772	3.488	-	3.00
3" X 2-1/2"	1.130	0.421	1.154	3.488	-	2.41
4" X 1-1/4"	1.264	0.500	0.720	4.614	0.311	5.42
4" X 1-1/2"	1.264	0.500	0.732	4.614	0.311	5.42
4" X 2"	1.264	0.500	0.772	4.614	0.311	5.36
4" X 2-1/2"	1.264	0.500	1.154	4.614	0.311	5.08
4" X 3"	1.264	0.500	1.213	4.614	-	5.23

**\*The material composition and quality comply with ASTM A351/A351M "Standard Specification for Castings, Austenitic, for Pressure-Containing Parts"**  
**\*NPT Threads on all fittings conform to ASME B1.20.1**  
**\*Dimensions comply with MSS SP-114**  
**\*\* Patterns shall be designed to produce castings of metal thickness given in table. Metal thickness at no point shall be less than 90% of the nominal metal thickness value.**