

DESIGN FEATURES:

- Built-in ISO 5211 Mounting Pad for Easy Automation
- Anti-Static Devices for Ball-Stem-Body
- Blow-out Proof Stem
- Pressure Balance Hole in Ball Slot
- Casting Boss on Body for Draining
- Options: 1. Actuator 2. Limit Switch 3. Positioner

APPLICABLE STANDARDS:

- Design: ASME B16.34, API 608
- Face to Face: ASME B16.10
- Wall Thickness: ASME B16.34
- End Flange: ASME B16.5
- Inspection & Testing: API 598, API 6D

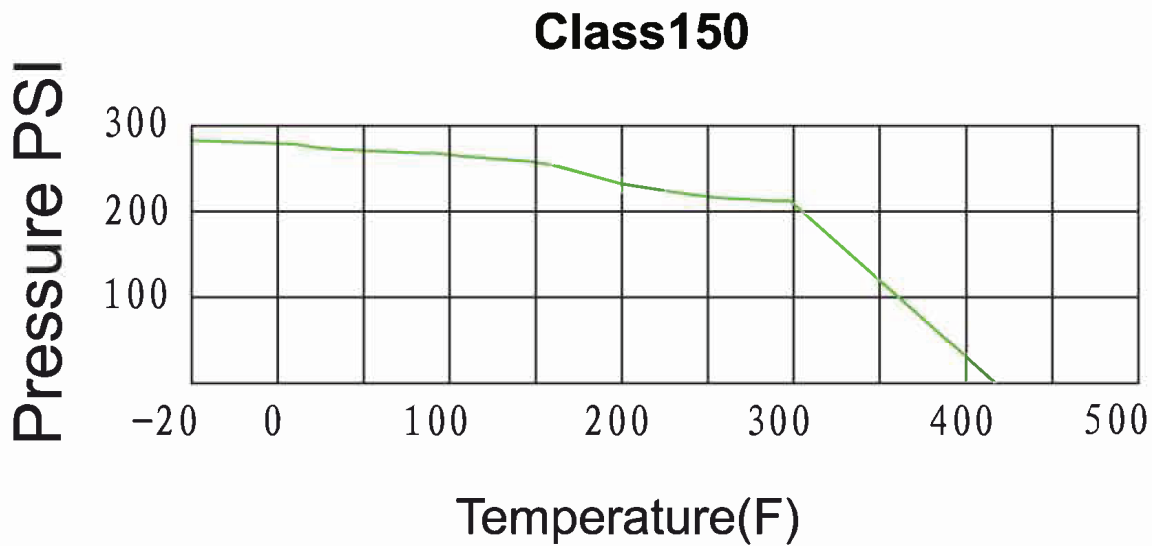

Cv, Weights & Port

Size	Cv	Wt (Lbs)	Port
1/2"	18	3.21	0.59
3/4"	36	4.97	0.79
1"	48	6.56	0.98
1-1/4"	72	7.57	1.26
1-1/2"	120	12.83	1.50
2"	190	18.59	1.97
2-1/2"	450	31.83	2.52
3"	600	38.94	2.99
4"	1100	67.47	3.93
6"	2600	161.07	5.90
8"	4200	276.96	7.87

Torques(in-lbs)

Size	Torque
1/2"	44
3/4"	53
1"	89
1-1/4"	115
1-1/2"	168
2"	252
2-1/2"	398
3"	637
4"	974
6"	2708
8"	3806

Headquarters:

One Merit Drive
 PO Box 43127
 Cleveland, OH 44143
 TEL: 216 261 9800
 TOLL FREE TEL: 800 726 9800
 TOLL FREE FAX: 855 MBFAXIT
 Email: mbsales@meritbrass.com
 Websites: www.meritbrass.com
www.MBWebXpress.com
www.MBLeadFree.com

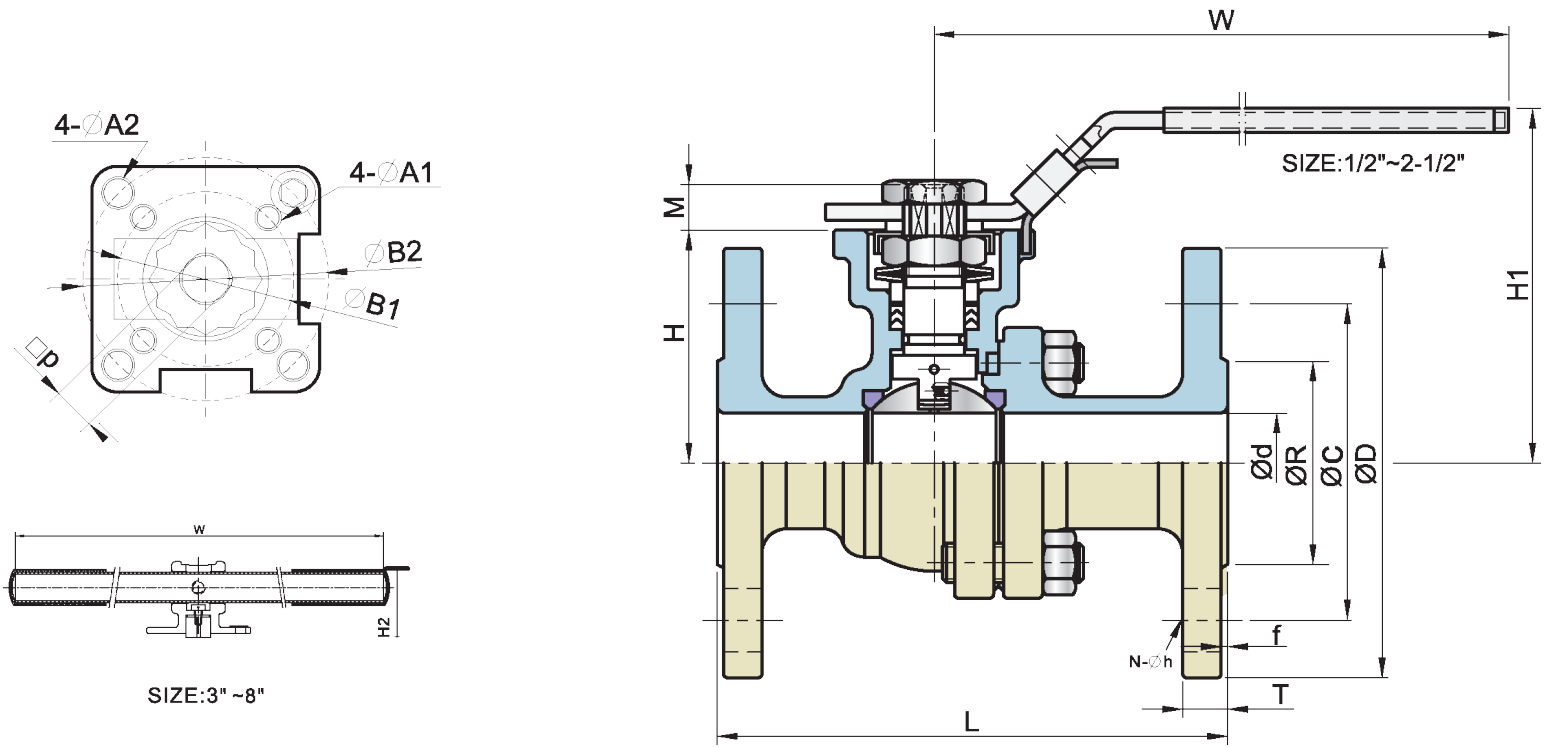

ASME CLASS 150

KFDMV2015FP

UNIT: INCH

SIZE	∅d	L	∅R	∅D	∅C	T	f	N	∅h	H	H1	H2	W	M	P	A1	A2	B1	B2	X	Y	ISO 5211	P-Actuator	E-Actuator	Pressure
1/2"	0.59	4.25	1.38	3.50	2.38	0.40	0.08	4	0.63	1.89	5.71	3.07	5.71	0.35	0.35	0.24	0.24	1.42	1.65	5.67	2.83	F03-F04	KP50	KQ006	80PSI
3/4"	0.79	4.61	1.69	3.88	2.76	0.43	0.08	4	0.63	2.09	5.91	3.31	5.71	0.35	0.35	0.24	0.28	1.42	1.97	5.67	2.83	F03-F05	KP50	KQ006	80PSI
1"	0.98	5.00	2.01	4.25	3.12	0.46	0.08	4	0.63	2.30	6.63	3.52	6.89	0.43	0.43	0.24	0.28	1.65	1.97	6.46	3.31	F04-F05	KP63	KQ006	80PSI
1-1/4"	1.26	5.51	2.50	4.61	3.50	0.52	0.08	4	0.63	2.80	7.13	3.98	6.89	0.43	0.43	0.24	0.35	1.65	2.76	6.46	3.31	F04-F07	KP63	KQ006	80PSI
1-1/2"	1.50	6.50	2.88	5.00	3.88	0.57	0.08	4	0.63	2.99	8.03	4.21	7.48	0.55	0.55	0.28	0.35	1.97	2.76	8.19	3.78	F05-F07	KP75	KQ008	80PSI
2"	1.97	7.01	3.62	6.00	4.75	0.64	0.08	4	0.75	3.19	8.23	4.41	7.48	0.55	0.55	0.28	0.35	1.97	2.76	8.19	3.78	F05-F07	KP75	KQ008	80PSI
2-1/2"	2.48	7.48	4.12	7.00	5.50	0.70	0.08	4	0.75	4.00	9.59	5.91	10.43	0.67	0.67	0.35	0.43	2.76	4.02	9.72	4.25	F07-F10	KP88	KQ015	80PSI
3"	2.99	7.99	5.00	7.50	6.00	0.77	0.08	4	0.75	4.39	10.45	6.93	11.81	0.67	0.67	0.35	0.43	2.76	4.02	10.55	4.84	F07-F10	KP100	KQ015	80PSI
4"	3.94	9.02	6.18	9.00	7.50	0.96	0.08	8	0.75	5.51	13.19	8.03	15.75	0.87	0.87	N/A	0.43	N/A	4.02	13.58	5.94	F10	KP125	KQ020	80PSI
5"	4.92	14.02	7.32	10.00	8.50	0.96	0.08	8	0.88	7.20	16.30	10.06	23.62	1.06	1.06	0.55	N/A	4.92	N/A	17.72	7.95	F12	KP160	KQ030	80PSI
6"	5.91	15.51	8.50	11.00	9.50	1.02	0.08	8	0.88	7.99	17.13	10.83	31.50	1.06	1.06	0.55	N/A	4.92	N/A	17.72	7.95	F12	KP160	KQ030	80PSI
8"	7.87	17.99	10.63	13.50	11.75	1.14	0.08	8	0.88	9.94	21.87	12.91	31.50	1.06	1.06	0.55	N/A	4.92	N/A	21.46	8.82	F12	KP200	KQ050	80PSI

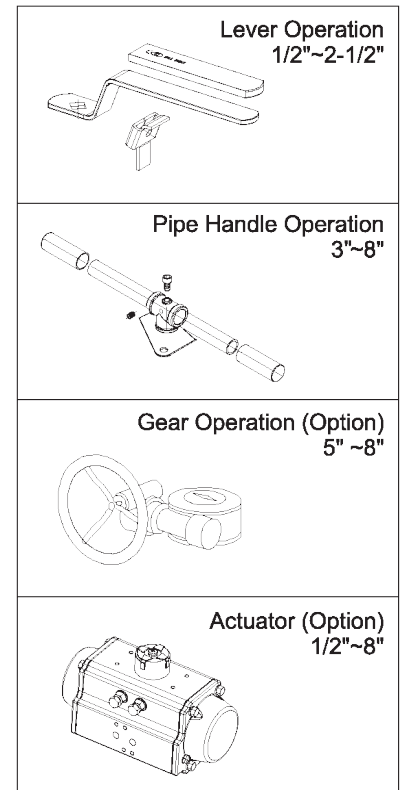
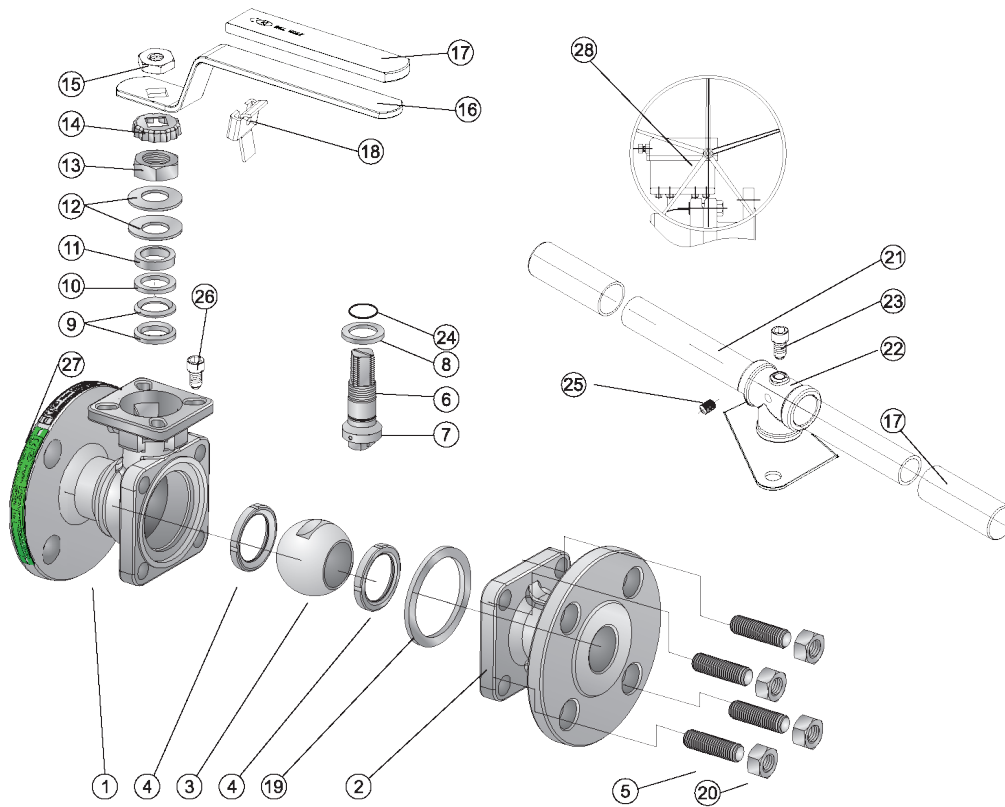

MATERIAL OF CONSTRUCTION

NO.	PART	MATERIAL		
		ANSI/JIS/DIN	ANSI/JIS/DIN	ANSI/JIS/DIN
1	Body	A351-CF8M/SCS14A/1.4408	A351-CF8/SCS13A/1.4308	A216-WCB/SCPH2/1.0619
2	End Cap	A351-CF8M/SCS14A/1.4408	A351-CF8/SCS13A/1.4308	A216-WCB/SCPH2/1.0619
3	Ball	A351-CF8M/SCS14A/1.4408	A351-CF8/SCS13A/1.4308	
4	Ball Seat	TFM1600/PTFE/RTFE		
5	Bolting	A193-B8 (For ANSI ball valves) / A2-70 (For DIN ball valves)		A193-B7 (For ANSI ball valves) / 8.8 (For DIN/JIS ball valves)
6	Stem	SUS316	SUS304	
7	Anti-Static	SUS316	SUS304	
8	Thrust Washer	PTFE		
9	Stem Packing	PTFE		
10	Bushing	50% SS + 50% PTFE		
11	Gland	SUS316		
12	Belleville Washer	SUS301		
13	Stem Nut	A194-8		
14	Stop-Lock-Cap	SUS304		
15	Handle Nut	A194-8		
16	Lever	SUS304		
17	Handle Sleeve	VINYL PLASTIC		
18	Lock Device	SUS304		
19	Body Gasket	PTFE		
20	Nut	A194-8 (For ANSI ball valves) / A2-70 (For DIN/JIS ball valves)		194-2H (For ANSI ball valves) / 8.8 (For DIN/JIS ball valves)
21	Pipe Handle (3"~8")	A53+Zn PLATED		
22	Handle Adapter (3"~8")	CF8		
23	Bolting (3"~8")	A2-70		
24	O-Ring	FKM		
25	Set Screwed (3"~8")	SUS304		
26	Stop Bolt	A193-B8		
27	Nameplate	SUS304		
28	Worm Gear	WCB		

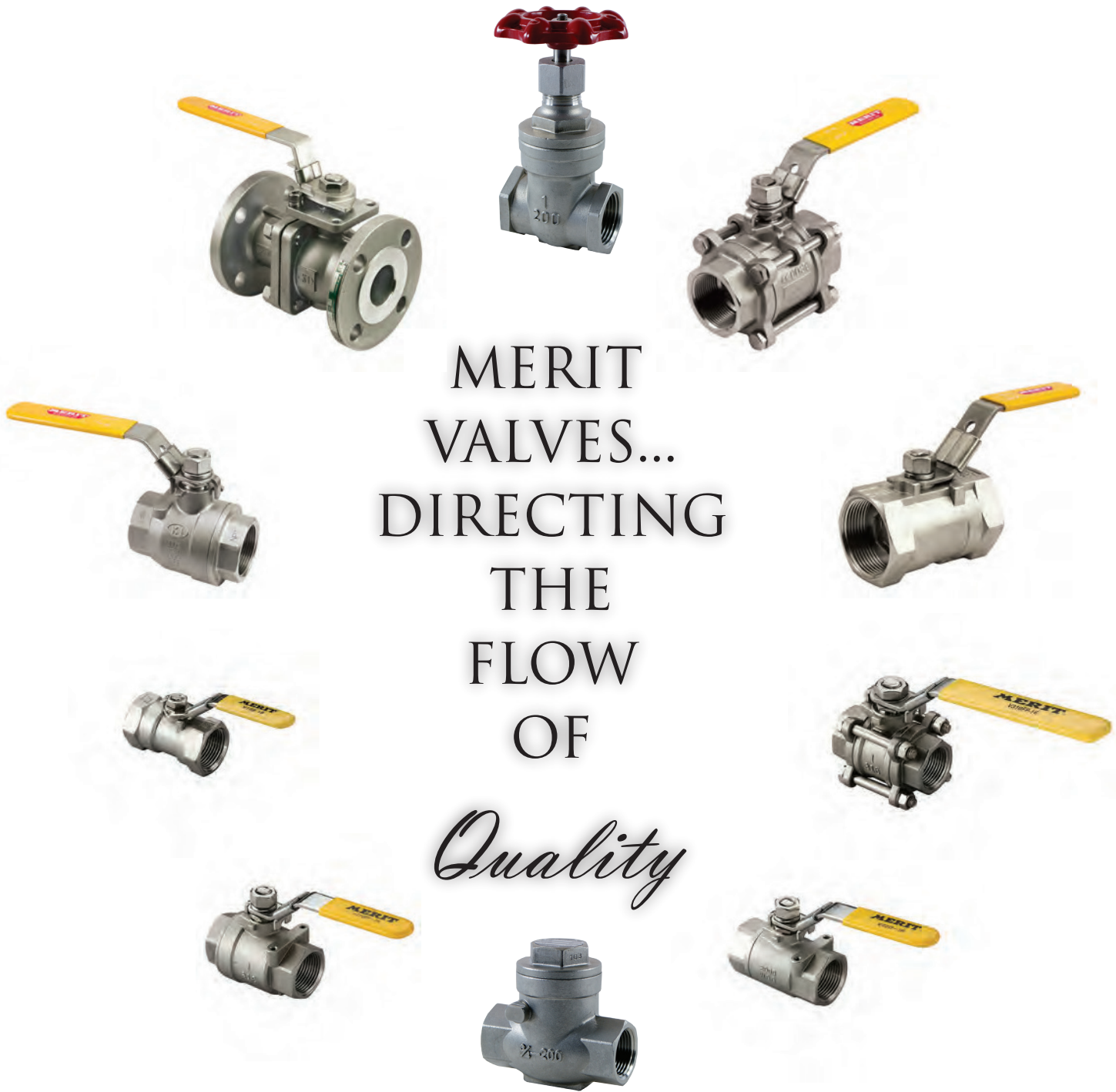

MERIT
VALVES...
DIRECTING
THE
FLOW
OF
Quality

VISIT US AT WWW.MERITBRASS.COM · WWW.MBWEBXPRESS.COM · WWW.MBLEADFREE.COM

CLEVELAND HEADQUARTERS:

Local Tel: 216-261-9800
Toll Free Tel: 800-726-9800
Toll Free Fax: 855-MBFAXIT
E-Mail: mbsales@meritbrass.com
Address: P.O. Box 43127, One Merit Drive
 Cleveland, OH 44143

DALLAS DISTRIBUTION CENTER:

Toll Free Tel: 877-259-2591
Toll Free Fax: 877-259-2596
E-Mail: mbsalesTX@meritbrass.com
Address: 10614 King William Drive
 Dallas, TX 75220

RENO DISTRIBUTION CENTER:

Toll Free Tel: 855-912-0408
Toll Free Fax: 877-376-0093
E-Mail: mbsalesNV@meritbrass.com
Address: 200 Vista Blvd., Suite #106
 Sparks, NV 89434

BIRMINGHAM DISTRIBUTION CENTER:

Toll Free Tel: 855-912-0409
Toll Free Fax: 866-668-9168
E-Mail: mbsalesAL@meritbrass.com
Address: 220 Oxmoor Court
 Birmingham, AL 35209

Merit Brass Cleveland Headquarters Has An ISO 9001:2015 Registered Quality Management System

