

Figures 220-DS, 220-US Lever & Weight Swing Check Valve

Description

GA Industries Figures 220-DS and 220-US are heavy duty, customizable swing check valves that utilize an adjustable counterweight assisted closure to minimize slam and hammer. The valve is typically installed in the discharge of a pump to prevent backflow when the pump is off line, it opens smoothly at pump start and closes quickly and quietly upon pump shutdown.

Figures 220-DS and 220-US meet the design, materials of construction and testing required by AWWA C508 and are suitable for use with water or sewage.



Product Features

- Heavy duty construction withstands rigors of pump station operation
- Full flow area when swung only 25° away from seat for low head loss and reduced pumping cost
- Replaceable rubber disc seat for tight seating at low and high pressure
- Lever & weight field convertible right hand to left hand side, and from horizontal to vertical installation

Standard Materials

- Body & Disc Cast Iron, ASTM A126 Class B
- Cover Steel, ASTM A36
- Body Seat Stainless Steel, Type 316
- Disc Seat Buna-N
- Hinge Shaft Stainless Steel, Type 303
- External Fasteners Steel, A307, Zinc Plated

Corrosion Protection

- Standard: Uncoated Internal, Enamel Primer External

See Option P2 and P3 for upgraded corrosion protection packages

Non-Shock Working Water Pressure at up to 150F (66C)			
Figure No.	220-DS		220-US
Flange	ANSI B16.1 Class 125		ANSI B16.1 Class 250
Size	3" to 12"	14" to 24"	3" to 12"
Max Working Pressure	200 PSI	150 PSI	300 PSI
Shell Test	400 PSI	300 PSI	450 PSI

Approvals & Certifications

- NSF-61 Certified for Contact with Drinking Water
- NSF-372 Certified Lead Free (Max 0.25% Lead Content by Weighted Average)

Options

- Option P2: Minimum 6 mil Internal and External 2-Part NSF-61 Carbolite 891 Epoxy and 316 SS External Fasteners
- Option P3: Minimum 6 mil Internal and External 2-Part NSF-61 Carbolite 891 Epoxy, 316 SS Hinge Shaft and External Fasteners
- Option 1D: With Honeywell HDLS NEMA 1, 3, 4, 4X, 6, 6P, 12 & 13 DPDT Limit Switch
- Option LH: With Lever & Weight Factory Installed on Left Side Facing Inlet
- Option VI: Configured for Vertical Flow Up Installation

Ordering Data

- Figure Number (220-DS or 220-US)
- Size
- Options and/or Accessories

Data Sheet 220.01B

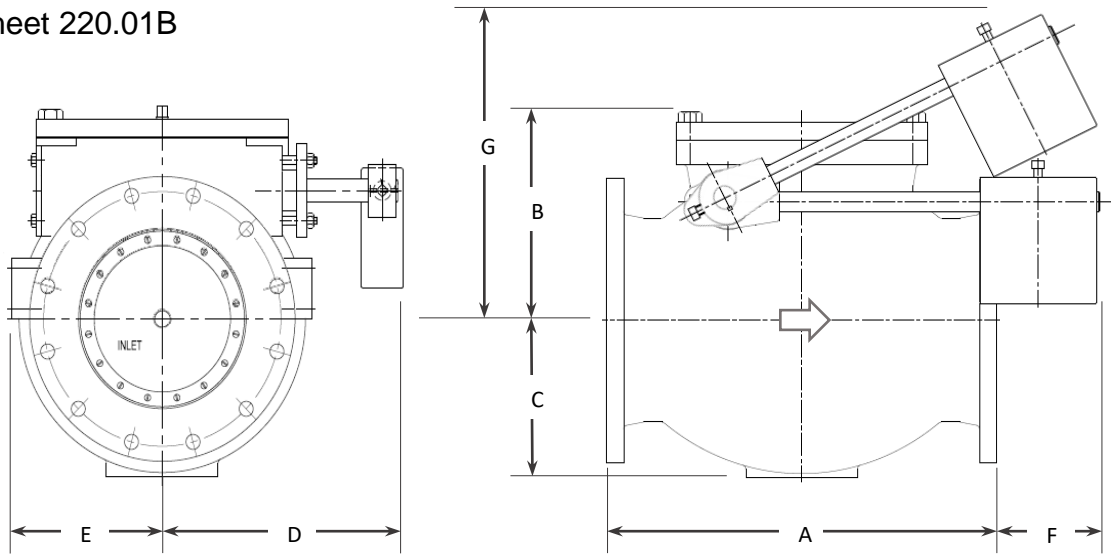

Installation Dimensions

SIZE	3"	4"	6"	8"	10"	12"	14"	16"	18"	20"	24"
A	12	13	17½	18	23	28	33	36	40	40	48
B	7	8½	9	12	14	16	22	23	24	24	28
C	5	5	6	9	9	11	13	14	17¼	17¼	20
D	10	11	12	14	15	17	20	24	28	28	36
E	5	5	7	8	9	11	14	16	18	18	21
F	5	4	3	3	--	8	-	-	--	--	1½
G	15	16	19	21	23	32	34	35	37	37	44
H	9¼	8½	10⅝	9	8	17	14¾	13¾	22½	22½	22½
WGT	100	150	230	310	480	970	1480	1800	2400	2800	6000

- Dimension G is valve fully open, Dimensions F and H are valve fully closed
- Face to face same for both Class 125 and Class 250 flanged valves, Class 250 supplied with flat face
- Larger sizes available, consult factory
- Dimensions in inches, weight in pounds and are approximate. Request certified drawings if critical.

Full Open Head Loss

