

Figure 340-W “Ludlow” Lever & Weight Swing Check Valve

Description

GA Industries Figure 340-W “Ludlow” swing check valve fully conforms with AWWA Standard C508 with an adjustable counterweight assisted closure to minimize slam and hammer. The valve is typically installed in the discharge of a pump to prevent backflow when the pump is off line, it opens smoothly at pump start and closes quickly and quietly upon pump shutdown.

The Figure 340-W meets the design, materials of construction, testing and face to face dimension required by AWWA C508 and is suitable for use with water or sewage.

Product Features

- Class 125 flanged 250 PSI rated epoxy coated ductile iron construction
- Tough and corrosion resistant 316SS body seat
- Buna-N rubber faced ductile iron disc for tight seating at low and high pressure
- Bolted cover with stainless steel cover fasteners facilitates maintenance

Standard Materials

- Body, cover & disc Ductile Iron, ASTM A536, Grade 65-45-12
- Body Seat Stainless Steel, Type 316
- Disc Seat Face Buna-N
- Hinge Shaft Stainless Steel, Type 303
- External Fasteners Stainless Steel, Type 316

Corrosion Protection

- Standard: Internal/external PPG/Amerlok 400 NSF-61 certified 2-part epoxy, minimum 6 mil DFT

Data Sheet 340W.01B



Approvals & Certifications

- Complies with AWWA Standard C508

Options/Accessories

- Option 1D With Honeywell HDLS NEMA 1, 3, 4, 4X, 6, 6P, 12 & 13 DPDT Limit Switch
- Option VI Configured for installation in vertical flow up pipe

Ordering Data

- Figure Number (340-W)
- Size
- Options and/or Accessories

Non-Shock Working Water Pressure at up to 150F (66C)	
Figure No.	340-W
Flange	ANSI B16.1 Class 125
Size	3" to 30"
Max Working Pressure	250 PSI
Hydro Test	500 PSI

Data Sheet 340W.01B

Installation Dimensions

SIZE	A	B	C	D	E	F	G	H	WGT
3"	9½	6¼	3	9¾	4¼	7	15	11	70
4"	11½	7½	3¾	10¼	5	5½	16	10	100
6"	14	9½	4⅞	12	6¼	6½	19	12	170
8"	19½	11¼	5	14¼	7¾	4	21	10	300
10"	24½	14½	7½	15¼	9¼	--	23	10	450
12"	27½	16½	9	16½	10¼	9	32	18	650
14"	31	17¾	10½	17½	11¼	2	34	16	950
16"	36	19½	11¾	22	12½	2	35	15	1200
18"	40	21¼	12¾	23¼	13½	--	37	24	1500
20"	40	23¼	14	24½	14¾	--	37	24	2000
24"	47¾	28¼	17¼	27	18½	1½	44	24	3000
30"	60	33	26	41	22	--	55	32	6000

- Dimension G is valve fully open, Dimensions F and H are valve fully closed
- Dimensions in inches, weight in pounds
- Dimensions and weights are approximate, request certified drawings if critical

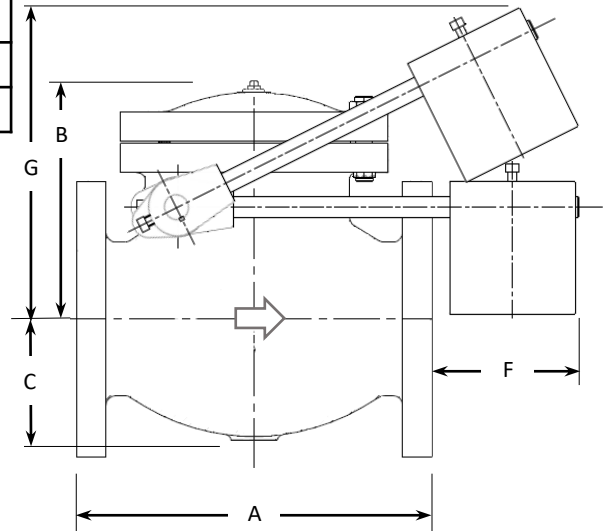
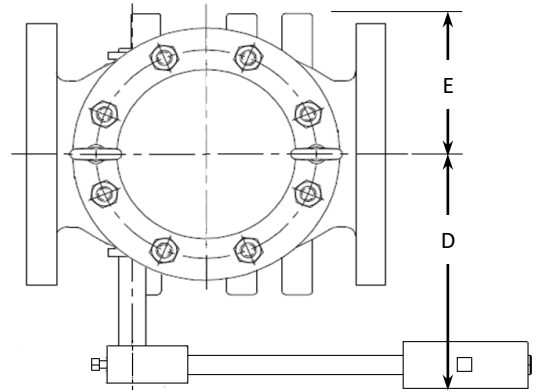

VERTICAL INSTALLATION

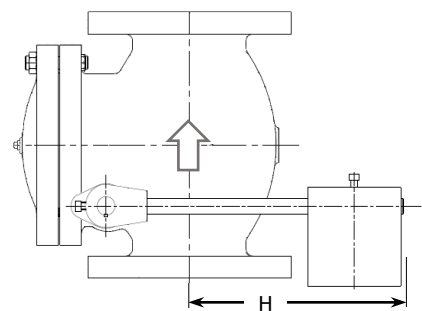

Full Open Head Loss

