

# 33XU-F

Cast Steel Gate Valve  
Rising Stem

Class 300

33XU-F



### Features & Benefits

- Efficient stop valves with flow in either direction
- Commonly used where a minimum pressure drop is important
- Flexible wedge disc compensates for deformation of body due to pipe stress
- Outside screw & yoke
- Flanged
- Seat ring is seal welded to eliminate leak paths

### Materials

PART	MATERIAL
Body	A216 WCB
Bonnet	A216 WCB
Seat Rings	Hardfaced
Disc	CA-15 or 13% CR Overlay
Stem	ASTM A182 F6a Cl. 2. This is equivalent to SS410
Packing	Graphite
Bonnet Gasket	ASTM A276 304 + Graphite
Back Seat	410 SS
Yoke	ASTM A216 WCB
Retaining Nut	Malleable or Steel
Disc Washer	Carbon Steel
Gland	Steel
Gland Flange	Steel
Eye Bolt	Steel
Eye Bolt Nuts	Steel
Pins	Steel
Bonnet Studs	A193 Gr. B7
Bonnet Nuts	A194 Gr. 2H
Handwheel	Malleable, Ductile or Steel
Handwheel Nut	Ductile or Steel
ID Tags	SS
ID Pins	Steel
Spacer	Steel
Grease Fittings	Steel

### Dimensional Drawing

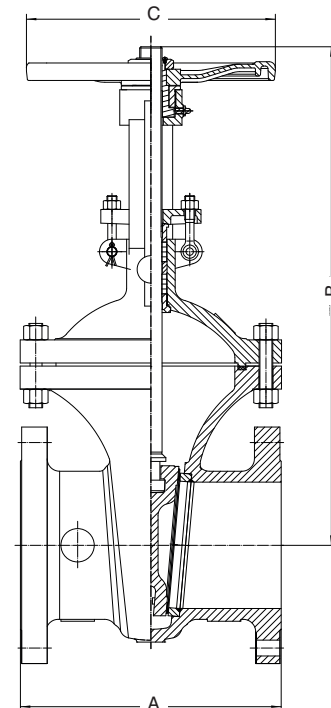

### Dimensions & Weights

SIZE (inch)	WEIGHT (kg)	A (mm)	B VALVE OPEN (mm)	C (mm)
2	24.42	216	408	200
2 1/2	32.93	241	460	200
3	46.08	282	530	240
4	72.83	305	619	280
6	141.17	403	826	360
8	216.67	419	1038	400
10	322	457	1247	450
12	480	502	1436	560

### Industry Standards

STEEL VALVES	ANSI B16.34
FACE-TO-FACE/END-TO-END	ANSI B16.10
FLANGE DIMENSIONS	ANSI B16.5
BASIC DESIGN	API 600
TESTING	API 598
ACCEPTANCE	API RP591

Intermediate pressure ratings shall be determined by interpolation.

**SIZE RANGE:** 2 -12 inches    **PRESSURE TEMPERATURE RATING:** Class 300

Carbon Steel  
ASTM A216 Grade WCB  
51.1 Bar / -29 to 38°C  
28.8 Bar / 425°C

Valid as of 081220

Every effort has been made to ensure that the information contained in this publication is accurate at the time of publishing. Crane Ltd assumes no responsibility or liability for typographical errors or omissions or for any misinterpretation of the information within the publication and reserves the right to change without notice.