

SCI Press–Carbon Dimensional Reference Comparison

Coupling Fig. SP704

	Size	ASC	Viega	Nibco	Mueller
L	½"	2.83	2.70	2.81	
	¾"	3.22	2.94	3.09	
	1"	3.58	3.26	3.36	
	1¼"	4.72	4.34	4.46	
	1½"	4.88	4.63	4.74	
	2"	5.11	4.71	4.86	
A	½"	0.78	0.56	0.61	0.52
	¾"	0.86	0.63	0.80	0.54
	1"	0.86	0.57	0.61	0.59
	1¼"	1.12	0.70	0.76	0.62
	1½"	1.18	0.89	0.88	0.67
	2"	1.26	0.77	0.84	0.84

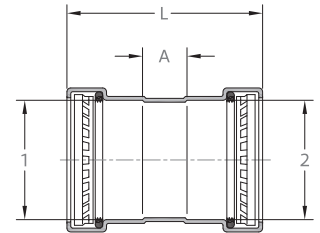

90° Elbow Fig. SP790

	Size	ASC	Viega	Nibco	Mueller
L	½"	2.57	2.24	2.30	
	¾"	3.01	2.52	2.54	
	1"	3.56	3.07	3.13	
	1¼"	4.46	3.82	3.86	
	1½"	4.78	4.13	4.20	
	2"	5.59	4.76	4.81	
A	½"	1.55	1.17	1.20	1.17
	¾"	1.83	1.36	1.40	1.37
	1"	2.20	1.72	1.75	1.96
	1¼"	2.66	2.00	2.01	2.28
	1½"	2.93	2.26	2.27	2.55
	2"	3.66	2.80	2.81	2.93

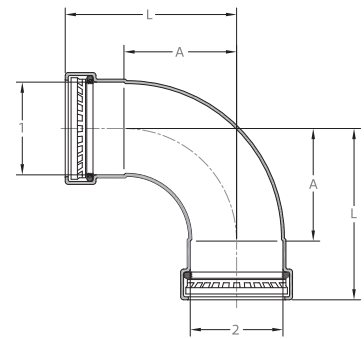

SCI Press-Carbon Dimensional Reference Comparison

Tees Fig. SP720

	Size	ASC	Viega	Nibco	Mueller
L1 & L2	½"	1.90	2.04	2.10	
	¾"	2.20	2.26	2.29	
	1"	2.53	2.57	2.63	
	1¼"	3.28	3.23	3.27	
	1½"	3.46	3.44	3.51	
	2"	3.85	3.78	3.83	
L3	½"	1.90	2.00	2.06	
	¾"	2.20	2.24	2.27	
	1"	2.53	2.57	2.63	
	1¼"	3.28	3.20	3.24	
	1½"	3.46	3.41	2.57	
	2"	3.85	3.77	3.81	
A1 & A2	½"	0.88	0.97	1.00	0.93
	¾"	1.02	1.11	1.15	1.06
	1"	1.18	1.23	1.26	1.22
	1¼"	1.48	1.41	1.42	1.40
	1½"	1.61	1.57	1.58	1.53
	2"	1.92	1.81	1.82	1.8
A3	½"	0.88	0.93	0.96	0.87
	¾"	1.02	1.09	1.13	0.98
	1"	1.18	1.23	1.26	1.18
	1¼"	1.48	1.38	1.39	1.39
	1½"	1.61	1.54	1.47	1.54
	2"	1.92	1.80	1.81	1.87

