

# SWING CHECK VALVE GROOVED



## Technical Features

- Connections: Grooved Ends (AWWA C606)
- Sizes: 2", 2-1/2", 3", 4", 5", 6", 8", 10", 12"
- Approvals: UL, ULC, and FM
- Maximum Working Pressure: 300PSI (Max. Test Pressure: 600PSI)
- Maximum Working Temperature: 250°F (120°C)
- Application: Indoor and Outdoor Use
- Low pressure-drop, Non-slam performance



PART	COMPONENT	MATERIAL	SPECIFICATION
1	BODY	Ductile Iron, Epoxy Coated	ASTM A536 65-45-12
2	CLAPPER	Stainless Steel	ANSI 304
3	COIL SPRING	Stainless Steel	ANSI 302
4	NUT	Stainless Steel	ANSI 304
5	BOLT	Stainless Steel	ANSI 304
6	WASHER	Rubber	ANSI 304
7	FACING SEAL	Stainless Steel	ANSI 304
8	SEAT RING	Ductile Iron	EPDM
9	DRAIN PLUG	Ductile Iron	ANSI 304
10	PIN PLUG	Aluminum Bronze	Drain Plug
11	BUSHING	Stainless Steel	Bushing
12	HINGE PIN	Steel	Hinge Pin
13	HOOK		Hook
14	OIL RING		EPDM
15	WASHER		ASTM A-307

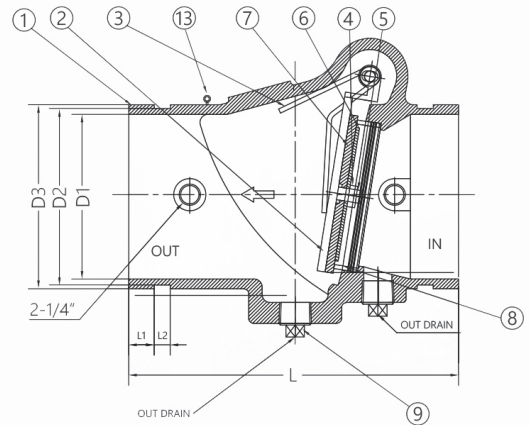

## DIMENSIONS

ITEM #	SIZE	D1	D2	D3	L	L1	L2
6520200	2"	1.9"	2.2"	2.4"	6.7"	0.6"	0.3"
6520201	2-1/2"	2.4"	2.7"	2.9"	7.2"	0.6"	0.3"
6520202	3"	2.9"	3.3"	3.5"	7.6"	0.6"	0.3"
6520203	4"	3.9"	4.3"	4.5"	8.1"	0.6"	0.3"
6520204	6"	6.1"	6.4"	6.6"	12.6"	0.6"	0.3"
6520205	8"	7.9"	8.5"	8.6"	14.6"	0.8"	0.4"
6520206	10"		10.6"	10.7"	18.0"	0.8"	0.5"

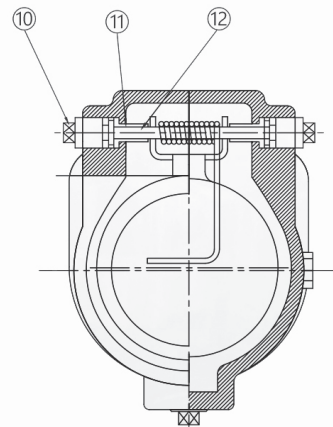

System No.		Location		Spec Section		Paragraph	
Submitted By		Date		Approved		Date	