

*** Maximum Operating Conditions**

Temperature (°F)	Maximum Pressure PSI
	12" & Smaller
170°	Up to 225
180°	Up to 200
190°	Up to 175
200°	Up to 150
210°	Up to 125
220°	Up to 100
230°	Up to 75

Contact factory for other elastomers. Not for steam applications.

NOTES:

WWW.ENGINEEREDFLEX.COM FOR INSTALLATION INSTRUCTIONS. JOINT MUST BE INSTALLED AT ITS NEUTRAL LENGTH. BOLTS MUST BE PROPERLY TORQUED. NOT SUITABLE FOR STEAM APPLICATIONS. **IF CONNECTING PIPE IS NOT ANCHORED AND GUIDED, CONTROL RODS MUST BE USED.**

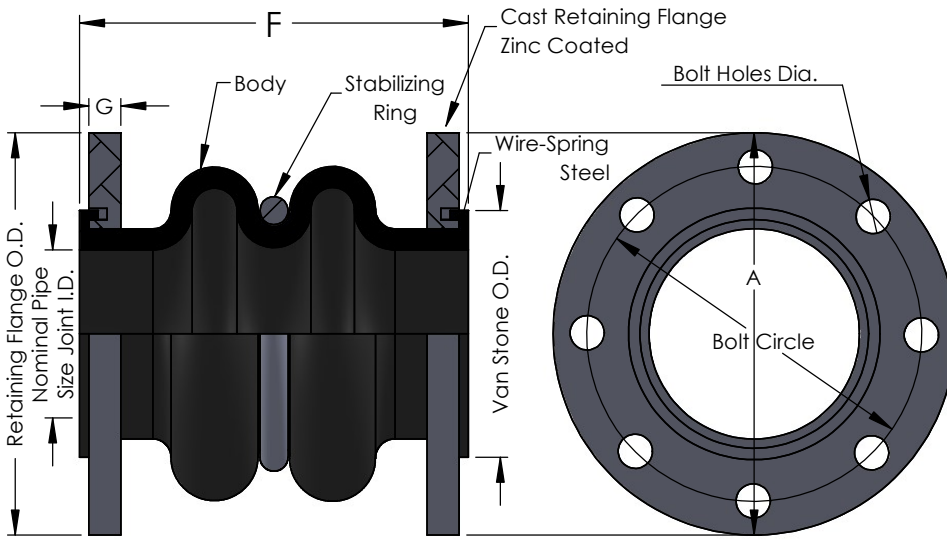

****When installing against a raised face flange - the use of a ring gasket is recommended.****

PIPE SIZE	Dimensions			Bolting			Movements				Physical			Approx. Weights			Materials			
	Pipe Size-Joint I.D.	F-Length of Joint	G-Flange Width	A-Flange/Ring O.D.	Flange Bolt Hole Circle	Number & Hole Size	Axial Compression	Axial Extension	Lateral Deflection	Angular Movements	Pressure Rating (PSIG)*	Vacuum Rating (In/Hg)	Temperature Rating*	Expansion Joint (lbs)	Control Unit Set (2)	Total Approx. wght (lbs)	Tube Elastomer	Cover Elastomer	Body Fabric	Body Reinforcing
1.5"	1.5"	7"	.55"	5"	3.88"	4 - .625"	2"	1.188"	1.75"	45°	225	26	230°F	6.8	-	6.8	EPDM	EPDM	Nylon	Fabric
2"	2"	7"	.63"	6"	4.75"	4 - .75"	2"	1.188"	1.75"	45°	225	26	230°F	9	-	9	EPDM	EPDM	Nylon	Fabric
2.5"	2.5"	7"	.71"	7"	5.5"	4 - .75"	2"	1.188"	1.75"	43°	225	26	230°F	13.3	-	13.3	EPDM	EPDM	Nylon	Fabric
3"	3"	7"	.71"	7.5"	6"	4 - .75"	2"	1.188"	1.75"	38°	225	26	230°F	14.3	-	14.3	EPDM	EPDM	Nylon	Fabric
4"	4"	9"	.71"	9"	7.5"	8 - .75"	2"	1.375"	1.562"	34°	225	26	230°F	20.3	-	20.3	EPDM	EPDM	Nylon	Fabric
5"	5"	9"	.79"	10"	8.5"	8 - .88"	2"	1.375"	1.562"	29°	225	26	230°F	24.5	-	24.5	EPDM	EPDM	Nylon	Fabric
6"	6"	9"	.87"	11"	9.5"	8 - .88"	2"	1.375"	1.562"	25°	225	26	230°F	29.5	-	29.5	EPDM	EPDM	Nylon	Fabric
8"	8"	13"	.87"	13.5"	11.75"	8 - .88"	2.375"	1.375"	1.375"	19°	225	26	230°F	43.8	-	43.8	EPDM	EPDM	Nylon	Fabric
10"	10"	13"	.95"	16"	14.25"	12-1"	2.375"	1.375"	1.375"	15°	225	26	230°F	65.5	-	65.5	EPDM	EPDM	Nylon	Fabric
12"	12"	13"	.95"	19"	17"	12-1"	2.375"	1.375"	1.375"	13°	225	26	230°F	95	-	95	EPDM	EPDM	Nylon	Fabric
14"	14"	13.75"	1.02"	21"	18.75"	12-1.13"	1.75"	1.118"	1.118"	9°	150	26	230°F	115	-	115	EPDM	EPDM	Nylon	Fabric

WARNING: Control units must be used to protect this part from excessive movement if piping is not properly anchored. Expansion Joints may operate in pipelines or equipment carrying fluids and/or gases at elevated temperature and pressures. Normal precautions should be taken to make sure these parts are installed correctly and inspected regularly. Precautions should be taken to protect personnel in the event of leakage or splash.

NSF 372 - LEAD FREE

The wetted surface of this product contacted by consumable water contains less than one quarter of one percent (0.25%) of lead by weight. Material complies with state codes and standards, where applicable, requiring reduced lead content.

REV. _____ DRAWN BY: CL _____ Date: 8/31/2020



5331 Quam Ave NE
St. Michael, MN 55376
Phone: 763-201-2151
Fax: 763-201-2134
Email: sales@engineeredflex.com

Style: **(302 SERIES) DOUBLE SPHERE EXP. JOINTS**

SCALE: NONE DRAWING NUMBER: _____

CUSTOMER: _____

PROJECT: _____